

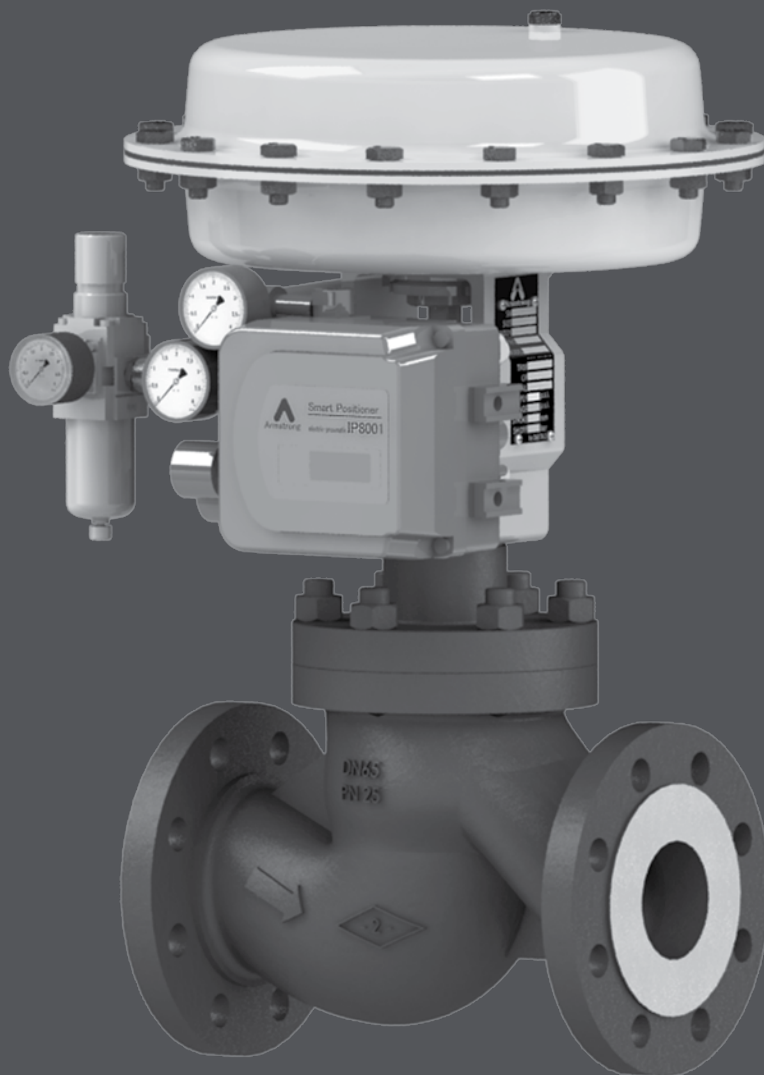

# FLY SERIES

2-WAY CONTROL VALVES





# Armstrong® Fly Series - Control Valves

## Product Features

Armstrong Delta2 - Fly Series is a single seat globe control valve with a robust construction designed for a wide range of process applications and easy maintenance.

- Size from DN15 to DN200 and from 1/2" to 8".
- DIN pressure rating from PN10 to PN100.
- ANSI pressure rating from 150 Lbs to 600 Lbs.

## Materials

Full range of materials and special alloys are available for valve body and trim including hardening treatment. Special NACE design and material construction for sour service with a compliance declaration in accordance to NACE regulations.

## Guiding

Valve guiding is top for standard parabolic plug. DN15 (1/2") to DN50 (2") is stem guided, DN65 (2-1/2") and bigger is shaft guided.

## Trim

Standard construction includes parabolic plug and threaded replaceable seat.

## Packing

Standard packing offers an internal self-adjusting spring system that provides low emissions according to the latest environmental regulations (TA-Luft and ISO-15848). In case of emission free request a bellow seal bonnet with different pressure ratings and materials are available.

## Severe Service

Single and double stage low-noise cage trim is available for most valve/trim sizes and designs. Single and double stage cavitation control trim is also available.

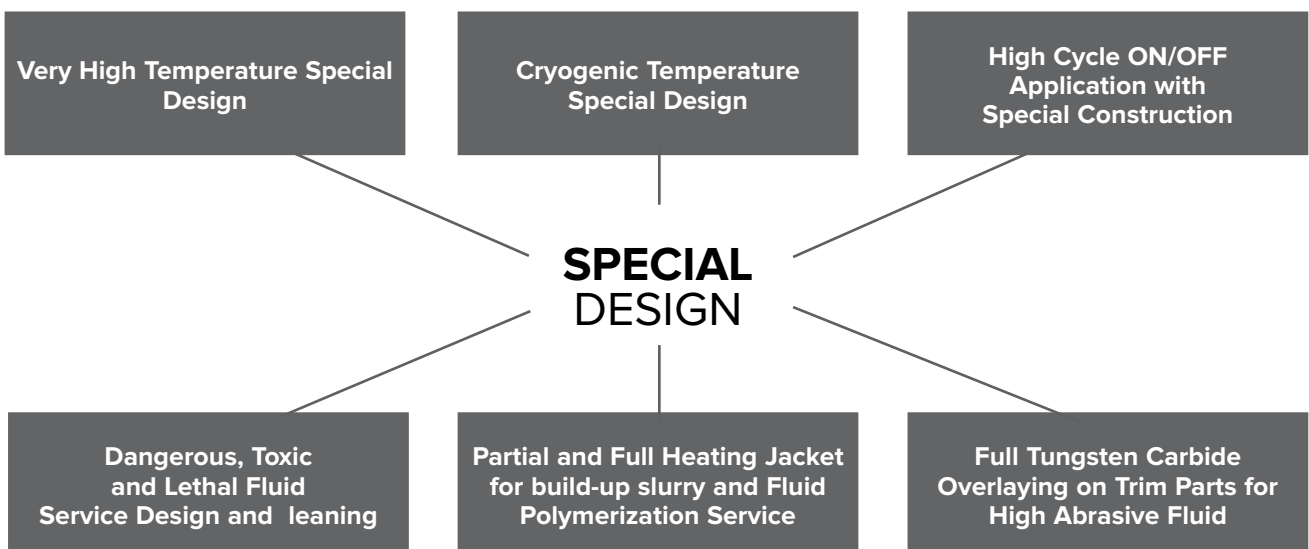

Designs, materials, weights and performance ratings are approximate and subject to change without notice. Visit [armstronginternational.com](http://armstronginternational.com) for up-to-date information.

# Fly Series - Control Valves

## Standard Part List

1	Body	11	Packing Gland Nut	21	Diaphragm Closing Plate
2	Seat	12	Locking Nut Ring	22	Diaphragm
3	Plug	13	Valve Bolts	23	Diaphragm Plate
4	Bonnet	14	Yoke	24	Spring
5	Body Gasket	15	Stroke Index	25	Spring Guide
6	Stem Bush Guide	16	Stem Plug Nut	26	Actuator Stem Nuts
7	Graphite Ring	17	Actuator Stem	27	Actuator Upper Housing
8	V-Rings	18	Lock nut	28	Actuator Bolts
9	Anti-Extrusion Ring	19	Actuator Shaft Guide	29	Actuator Nuts
10	Packing Spring	20	Shaft Bushing	30	Actuator Lower Housing

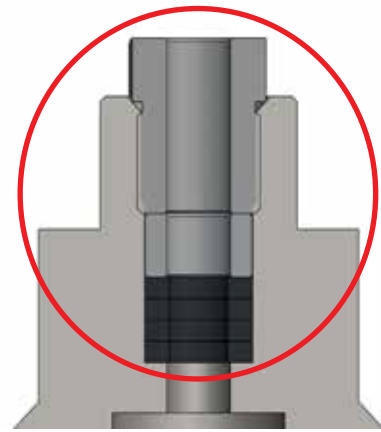
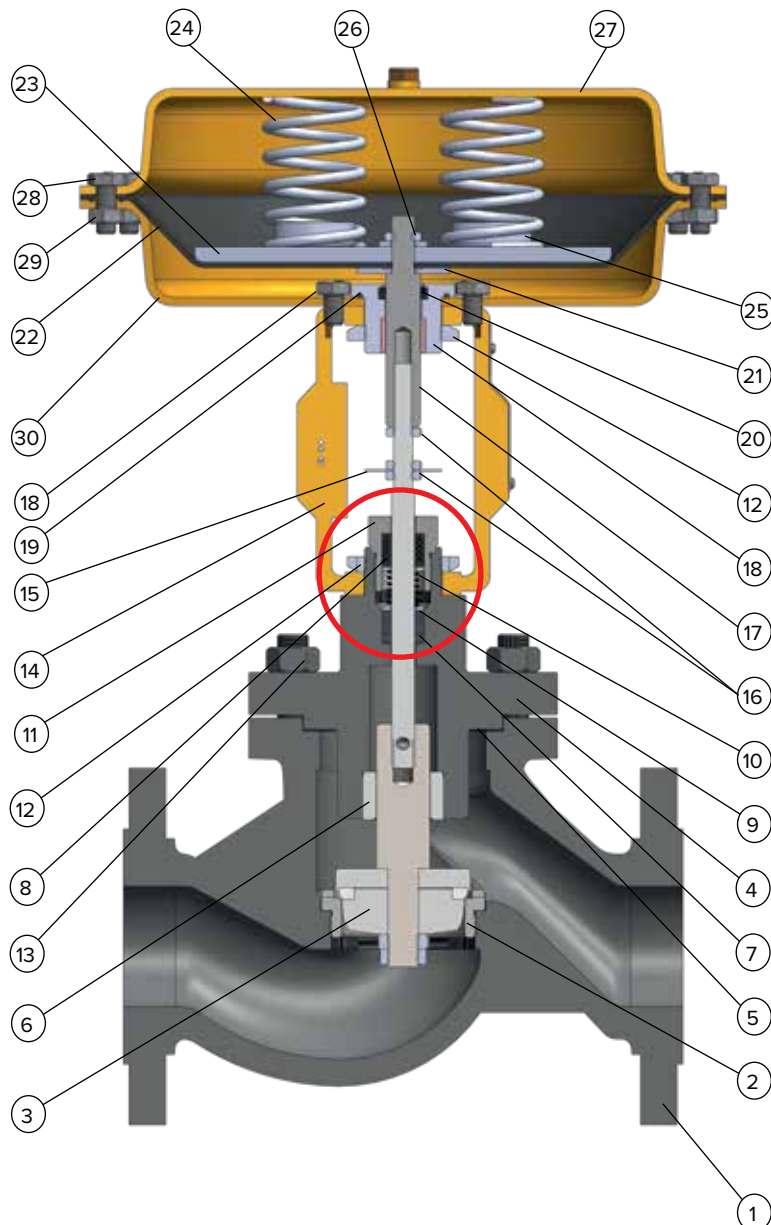

Pure Graphite

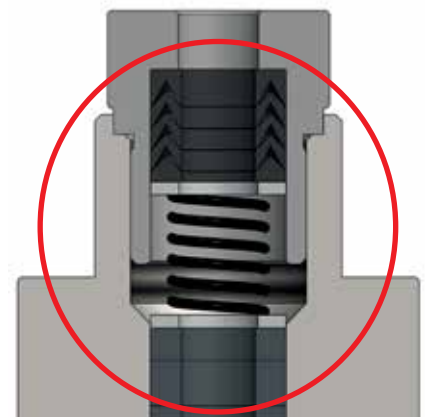

Euro

Designs, materials, weights and performance ratings are approximate and subject to change without notice.  
 Visit [armstronginternational.com](http://armstronginternational.com) for up-to-date information.

Single Stage Perforated Plug



Bellow Seal Bonnet

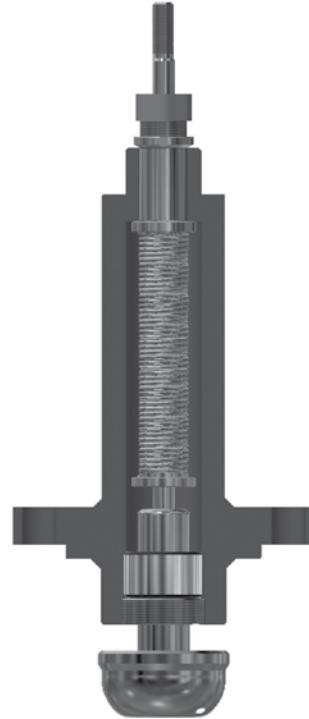

Standard Balanced Plug



Plug Guide



Designs, materials, weights and performance ratings are approximate and subject to change without notice. Visit [armstronginternational.com](http://armstronginternational.com) for up-to-date information.

# Valve Specification

Specifications	EN / DIN	ASME
Valve Construction	EN 12516	ANSI B 1634
Valve Body Size	DN15, 20, 25, 32, 40, 50, 65, 80, 100, 125, 150, 200 <b>(1)</b>	NPS 1/2, 3/4, 1, 1-1/4, 1-1/2, 2, 2-1/2, 3, 4, 5, 6, 8 <b>(1)</b>
Pressure Rating	From PN10 to PN100 as per EN1092-1	From CL150 to CL600 as per ASME B16.34
End Connections (See table on page 6 for detail)	Flanged raised face per EN1092-1 (Standard) Flanged Ring Joint / Threaded Ends / Welded Ends (Optional)	Flanges raised face per ASME B16.5 (Standard) Flanged Ring Joint / Threaded Ends / Welded Ends (Optional)
Face-to-Face Standard	EN558-1 / DIN 3202	ANSI / ISA 75.08.01 <b>(2)</b>
Shutoff per IEC 60534-4 and ANSI/FCI 70-2	Metal seat - Class IV (standard) Metal seat - Class V (optional) - PTFE seat - Class VI (optional) (For 4.8 to 14 mm ports, Class VI shutoff is achieved without PTFE seat)	
Flow Direction	Flow-up (Cavitation Control trim, Flow down)	
Flow Control Characteristics	Modified Equal Percentage, Equal Percentage, Linear and Quick Open	

**(1)** Other valve body connection sizes available on request.

**(2)** ISA S75.03 or special standard on request.

Trim Style	Port Diameters	Trim Style Description
Microflow	From 3 to 6 mm <b>(3)</b>	Low-Flow and Micro-Flow trim (unbalanced) Top Shaft Guided
Standard Parabolic Plug	From 8 to 250 mm <b>(1) (2)</b>	Parabolic Plug with Stem Guided ≤ DN50 Shaft Guided > DN50
Severe Service Trim (Option)	From 25 to 250 mm <b>(1) (2)</b>	Low-Noise Trim and Cavitation Control Trim with Top and cage Guided
Balance Plug (Option)	From 50 to 250 mm <b>(1)</b>	Parabolic, Low-Noise and Cavitation Control trim with Top Balancing Design

**(1)** Special high capacity trim are available on request.

**(2)** Standard rangeability 50:1. Optional higher rangeabilities can be provided.

**(3)** Standard rangeability for Microflow trim 30:1.

Standard EN / DIN	PN10-16					DIN PN25-40					PN63-100				
	B	D	SW	BW	THD	B	D	SW	BW	THD	B	D	SW	BW	THD
15															
20															
25															
32															
40															
50															
65															
80															
100															
125															
150															
200															

Standard Facing according to EN 1092-1 Form B1 up to PN40 and Form B2 above.

Standard ASME	Cl. 150					Cl. 300					Cl. 600				
	RF	RTJ	SW	BW	THD	RF	RTJ	SW	BW	THD	RF	RTJ	SW	BW	THD
1/2"															
3/4"															
1"															
1-1/4"															
1-1/2"															
2"															
2-1/2"															
3"															
4"															
5"															
6"															
8"															

Standard Facing according to ASME B16.5 Form RF (Ra 125-250 AARH Smooth Finish).

	Available
	Not available

# Materials of Construction

		Basic Materials according to ASME	Basic Materials according to DIN	Special Material
Valve Body	Ductile Iron	ASTM A395 / EN-GJS-400-18-LT / 0.7043	EN-GJS-400-18-LT / 0.7043	High Temp Alloy Steel ASTM A217 WC6 / W-No. 1.7357
	Carbon Steel	ASTM A216 WCB / EN_GP-240-GH / 1.0619	EN_GP-240-GH / 1.0619	Low Temp Alloy Steel ASTM A352 LCB / W-No. 1.6220
	Stainless Steel	ASTM A351 CF8M / 1.4408	G-X -6CrNiMo 18-10 / 1.4408	-
Plug	Stainless Steel	316L SS / W-No. 1.4404	X2CrNiMo 17-13-2 / 1.4404	Special materials available on request
	Stainless Steel	316L SS / W-No. 1.4404 + Partial / Full Stellite 6 Overlaying	X2CrNiMo 17-13-2 / 1.4404 + Partial / Full Alloy 6 Overlaying	Special materials available on request
	Stainless Steel	316L SS / W-No. 1.4404 + PTFE/RPTFE Soft Insert	X2CrNiMo 17-13-2 / 1.4404 + PTFE/RPTFE Soft Insert	Special materials available on request
	Stainless Steel	440C SS / W-No. 1.4125 + temper hardening , 17-4PH SS / W-No. 1.4548	X105CrMo17 / 1.4125 Hardened, X 5 CrNiCuNb 16-4-4 / 1.4548	Special materials available on request
Balancing Seal Rings	Carbon-Filled PTFE Seal V-Rings	Carbon-Filled PTFE Seal V-Rings	Carbon-Filled PTFE Seal V-Rings	Special materials available on request
	Reinforced-Graphite Seal rings for high temperatures	Reinforced-Graphite Seal rings for high temperatures	Reinforced-Graphite Seal rings for high temperatures	Special materials available on request
	Spring energized Rings or Steel rings for special application	Spring energized Rings or Steel rings for special application	Spring energized Rings or Steel rings for special application	Special materials available on request
Seat	Stainless Steel	316L SS / W-No. 1.4404	X2CrNiMo 17-13-2 / 1.4404	Special materials available on request
	Stainless Steel	316L SS / W-No. 1.4404 + Partial/Full Stellite 6 Overlaying	X2CrNiMo 17-13-2 / 1.4404	Special materials available on request
	Stainless Steel	440C SS / W-No. 1.4125 + temper hardening, 17-4PH SS / W-No. 1.4548	X105CrMo17 / 1.4125 Hardened, X 5 CrNiCuNb 16-4-4 / 1.4548	Special materials available on request
Stem	Stainless Steel	316L SS / W-No. 1.4404 Strain hardened	X2CrNiMo 17-13-2 / 1.4404 Strain hardened	Special materials available on request
	Stainless Steel	316L SS / W-No. 1.4404 + Alloy 6 overlaying	X2CrNiMo 17-13-2 / 1.4404 + Alloy 6 Overlaying	Special materials available on request
	Stainless Steel	440C SS / W-No. 1.4125 Treated, 17-4PH SS / W-No. 1.4548 Treated	X105CrMo17 / 1.4125 Hardened, X 5 CrNiCuNb 16-4-4 / 1.4548	Special materials available on request

Designs, materials, weights and performance ratings are approximate and subject to change without notice. Visit [armstronginternational.com](http://armstronginternational.com) for up-to-date information.

	Basic Materials according to ASME	Basic Materials according to DIN	Special Material
Packing Gland	Chrome plated Brass Special version with 316 SS available		
Bolts	ASTM A193-B7	42CrMo4	W-No. 1.7225
Nuts	ASTM A194-2H		W-No. 1.1191
Bolts	ASTM A193-B8	X5CrNi18-09	W-No. 1.4301
Nuts	ASTM A194-8		W-No. 1.4301
Packing	Internal Fix-loaded RPTFE V-rings + Graphite Ring with 316 SS spring. (1) (2) Internal Live-loaded RPTFE V-rings + Graphite Ring with 316 SS spring. (1) (2) “EURO” packing Internal Fix-loaded RPTFE V-rings + Triple Reinforced Graphite Rings with 316 SS spring. (1) (2) “EURO” packing Internal Live-loaded RPTFE V-rings + Triple Reinforced Graphite Rings with 316 SS spring. (1) (2) Internal Live-loaded Triple Reinforced Graphite Rings with 316 SS spring. (2) Special packing set available on request.		
Bonnet Gasket	Laminated Graphite or Virgin PTFE Spyrometallic SS/graphite or Inconel/graphite Special gaskets set on request.		

**(1)** = 15% Glass or 25% Graphite PTFE reinforced rings.

**(2)** = Low Emission packing are standard.

Metal Bellow seal with backup PTFE or Graphite rings to guarantee zero leakage.

Extra leak-off connection with secondary packing can be provided on request





# Materials of Construction

Multi-Spring Diaphragm Actuator Materials				
Actuator Housing	Carbon Steel (Standard)	Stainless Steel - rough finish	Stainless Steel - satinated finish	Stainless Steel - polished finish
Yoke Type	Cast Iron (Standard)	Low Temperature Carbon Steel	Carbon Steel Pillar Yoke	Stainless Steel Pillar Yoke
Diaphragm	Reinforced NBR (Standard)		Reinforced Silicon or FKM as Special on request	
Bolting	Carbon Steel B7/2H (Standard)	Stainless Steel B8/8	Carbon Steel NACE B7M/2HM	Stainless Steel NACE B8M/8M
Exhaust Screw Cap	Synterized Brass (Standard)		Stainless Steel	
Coating	Epoxy powder RAL 1028 (Standard)	Surface preparation with sandblasting and Inorganic zinc primer		Several Corrosion resistant coatings

**(1)** = Special materials available on request

Multi-Spring Piston Actuator Materials				
Actuator Housing	Carbon Steel (Standard)		Stainless Steel - rough finish	
Yoke Type	Carbon Steel Pillar Yoke		Stainless Steel Pillar Yoke	
Piston Seal Rings	Reinforced NBR (Standard)		Energized Fluoro-silicon or FKM as Special on request	
Bolting	Carbon Steel B7/2H (Standard)	Stainless Steel B8/8	Carbon Steel NACE B7M/2HM	Stainless Steel NACE B8M/8M
Exhaust Screw Cap	Synterized Brass (Standard)		Stainless Steel	
Coating	Epoxy powder RAL 1028 (Standard)	Surface preparation with sandblasting and Inorganic zinc primer		Several Corrosion resistant coatings



# Armstrong® Pressure and Temperature Ratings

Body & Bonnet Material	Bonnet Style	Packing	Body Gasket	Trim Style	Temperature	
					Unit °C	Min / Max
DIN 0.7043 ASTM A395 (GJS400-18) Ductile Iron	Standard	RPTFE Graphite	Graphite laminate or PTFE	Soft (All Severe Service Trim)	-10	210
	HT Extension	Graphite	Graphite laminated	Metal (All Severe Service Trim)	-10	350
	Bellow Seal	RPTFE	Graphite laminate or PTFE	Soft (All Severe Service Trim)	-10	210
		Graphite	Graphite laminated	Metal (All Severe Service Trim)	-10	350
DIN 1.0619 ASTM A216 WCB Carbon Steel	Standard	RPTFE Graphite	Graphite laminate or PTFE (Spyrometallic)	Soft (All Severe Service Trim)	-29	210
	HT Extension	Graphite	Graphite laminate (Spyrometallic)	Metal (All Severe Service Trim)	-29	427
	Bellow Seal	RPTFE	Graphite laminate or PTFE (Spyrometallic)	Soft (All Severe Service Trim)	-29	210
		Graphite	Graphite laminate (Spyrometallic)	Metal (All Severe Service Trim)	-29	427
DIN 1.4408 ASTM A351 CF8M Stainless Steel	Standard	RPTFE Graphite	Graphite laminate or PTFE (Spyrometallic)	Soft (All Severe Service Trim)	-60	210
	HT Extension	Graphite	Graphite laminate or PTFE (Spyrometallic)	Metal (All Severe Service Trim)	-60	600+
	Cryo Design	RPTFE Graphite	Graphite laminate (Spyrometallic)	Metal (All Severe Service Trim)	-196	210
	Bellow Seal	RPTFE	Graphite laminate or PTFE (Spyrometallic)	Soft (All Severe Service Trim)	-60	210
Graphite		Graphite laminate (Spyrometallic)	Metal (All Severe Service Trim)	-60	600+	
DIN 1.6220 ASTM A352 LCB Low Temp Alloy Steel	Standard	RPTFE Graphite	Graphite laminate or PTFE (Spyrometallic)	Soft (All Severe Service Trim)	-46	210
	HT Extension	Graphite	Graphite laminate (Spyrometallic)	Metal (All Severe Service Trim)	-46	250
	Bellow Seal	RPTFE	Graphite laminate or PTFE (Spyrometallic)	Soft (All Severe Service Trim)	-46	210
		Graphite	Graphite laminate (Spyrometallic)	Metal (All Severe Service Trim)	-46	250
DIN 1.5419 ASTM A217 WC6 High Temp Alloy Steel	Standard	RPTFE Graphite	Graphite laminate or PTFE (Spyrometallic)	Soft (All Severe Service Trim)	-29	210
	HT Extension	Graphite	Graphite laminate (Spyrometallic)	Metal (All Severe Service Trim)	-29	538+
	Bellow Seal	RPTFE	Graphite laminate or PTFE (Spyrometallic)	Soft (All Severe Service Trim)	-29	210
		Graphite	Graphite laminate (Spyrometallic)	Metal (All Severe Service Trim)	-29	538+

Designs, materials, weights and performance ratings are approximate and subject to change without notice. Visit [armstronginternational.com](http://armstronginternational.com) for up-to-date information.

# Pressure and Temperature Curves

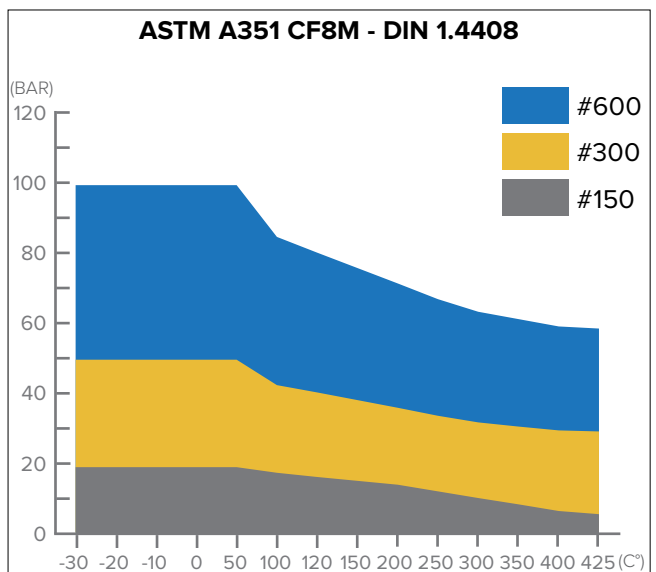
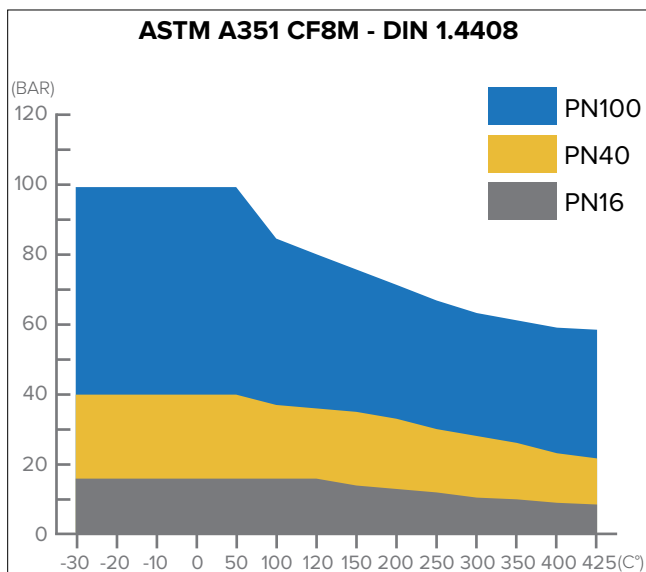
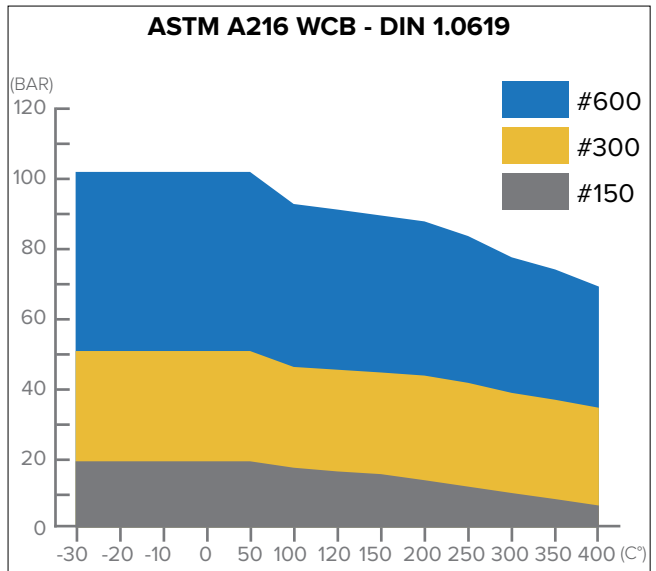
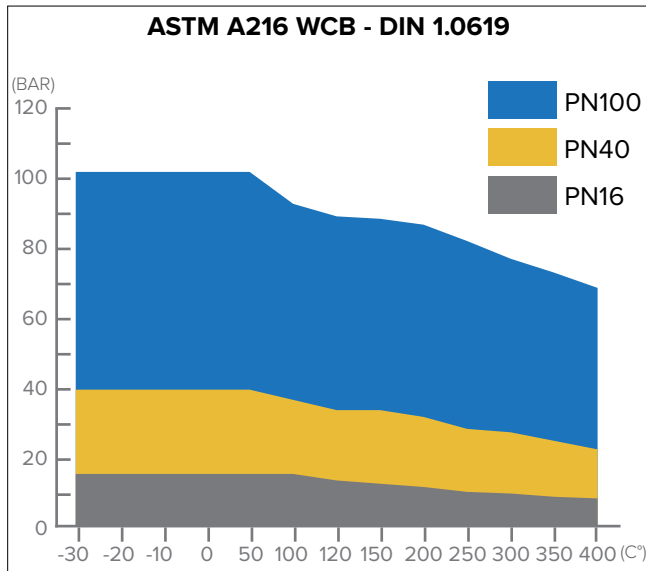
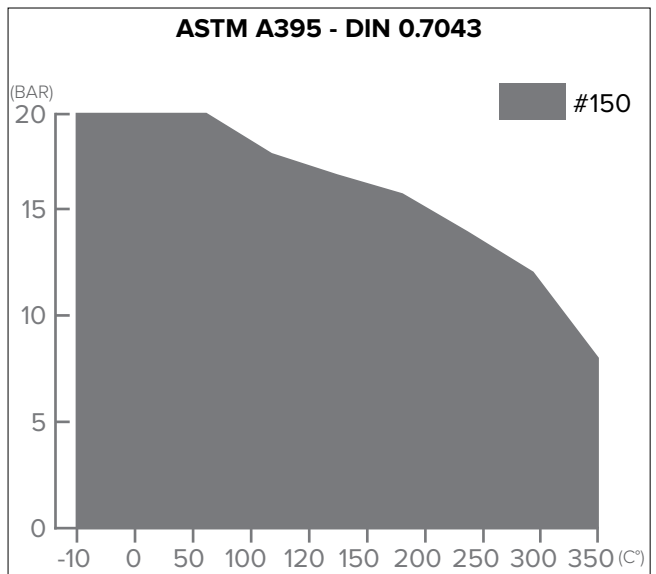
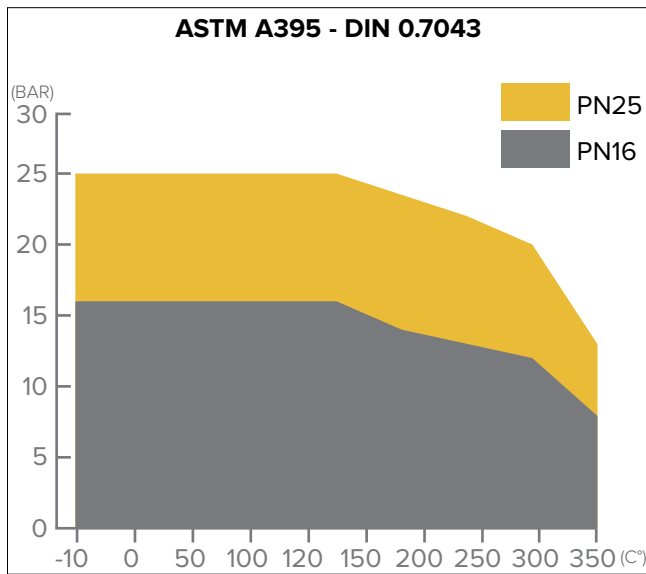

Designs, materials, weights and performance ratings are approximate and subject to change without notice.  
 Visit [armstronginternational.com](http://armstronginternational.com) for up-to-date information.



# Armstrong® Flow Coefficient Table

KV (CV)	Seat Diameter mm (inch)	Stroke mm (inch)	Nominal Diameter											
			15 1/2"	20 3/4"	25 1"	32 1.1/4"	40 1.1/2"	50 2"	65 2.1/2"	80 3"	100 4"	125 5"	150 6"	200 8"
≤ 0.05 (≤ 0.059) (1)	3 (1/8)	16 (5/8)												
0.13 (0.15)	6 (1/4)	16 (5/8)												
0.26 (0.3)	6 (1/4)	16 (5/8)												
0.43 (0.5)	6 (1/4)	16 (5/8)												
0.65 (0.75)	6 (1/4)	16 (5/8)												
0.9 (1.0)	6 (1/4)	16 (5/8)												
1.1 (1.3)	9 (1/3)	16 (5/8)												
1.3 (1.5)	10 (2/5)	16 (5/8)												
1.7 (2.0)	12 (1/2)	16 (5/8)												
2.0 (2.3)	12 (1/2)	16 (5/8)												
2.6 (3.0)	12 (1/2)	16 (5/8)												
4.18 (4.95)	15 (3/5)	16 (5/8)	Standard	Standard	Standard	Standard	Standard	Standard						
5.94 (6.93)	19 (3/4)	16 (5/8)	Standard	Standard	Standard	Standard	Standard	Standard						
10.45 (12.1)	25 (1.0)	16 (5/8)	Standard	Standard	Standard	Standard	Standard	Standard	Standard					
16.94 (19.8)	32 (1.1/4)	19 (3/4)	Standard	Standard	Standard	Standard	Standard	Standard	Standard	Standard				
28.6 (33)	40 (1.1/2)	19 (3/4)	Standard	Standard	Standard	Standard	Standard	Standard	Standard	Standard	Standard			
44 (51.26)	50 (2.0)	19 (3/4)	Standard	Standard	Standard	Standard	Standard	Standard	Standard	Standard	Standard	Standard		
68.64 (79.97)	64 (2.1/2)	25 (1.0)	Standard	Standard	Standard	Standard	Standard	Standard	Standard	Standard	Standard	Standard	Standard	
99 (115.5)	76 (3.0)	28 (1.0)	Standard	Standard	Standard	Standard	Standard	Standard	Standard	Standard	Standard	Standard	Standard	Standard
150.7 (176)	100 (4.0)	28 (1.1/9)	Standard	Standard	Standard	Standard	Standard	Standard	Standard	Standard	Standard	Standard	Standard	Standard
253 (293.7)	126 (5.0)	45 (1.7/9)	Standard	Standard	Standard	Standard	Standard	Standard	Standard	Standard	Standard	Standard	Standard	Standard
347.6 (404.8)	151 (6.0)	50 (2.0)	Standard	Standard	Standard	Standard	Standard	Standard	Standard	Standard	Standard	Standard	Standard	Standard
610.5 (711.7)	201 (8.0)	50 (2.0)	Standard	Standard	Standard	Standard	Standard	Standard	Standard	Standard	Standard	Standard	Standard	Standard

Available  
 Standard

<b>KV</b> = flowrate in m <sup>3</sup> /h with 1 bar of differential Pressure
<b>CV</b> = flowrate in USGPM with 1 psi of differential Pressure

**Options:**

- Special High Flow Coefficient available on request.
- Partial Hard Facing available starting from Seat Diameter 10mm and higher.
- Full Hard Facing through Overlaying or Treatments available for all Port Size.
- Special Soft Seating for Port Size < 10mm available on request.
- Special microflow CV trim are available on request.

Designs, materials, weights and performance ratings are approximate and subject to change without notice. Visit [armstronginternational.com](http://armstronginternational.com) for up-to-date information.

# Pneumatic Actuators Specifications



Actuator type	Ambient Temperature Limits with Standard Materials	Ambient Temperature Limits with Special Materials	Rating	Maximum Allowable Stem Thrust (1)			
				Stem size 12 mm	Stem size 16 mm	Stem size 20 mm	Stem size 24 mm
S.200	-20°C to +70°C	-40°C to +70°C or -20°C to +100°C	PN6	10.8 KN (Max port 32mm)	18.4 KN (Max port 32mm)		
S.275	-20°C to +70°C	-50°C to +70°C or -20°C to +120°C	PN6	10.8 KN (Max port 50mm)	18.4 KN (Max port 50mm)	31.2 KN (Max port 50mm)	
S.335	-20°C to +70°C	-50°C to +70°C or -20°C to +120°C	PN6	10.8 KN (Max port 80mm)	18.4 KN (Max port 100mm)	31.2 KN (Max port 100mm)	44.8 KN (Max port 100mm)
S.430	-20°C to +70°C	-50°C to +70°C or -20°C to +120°C	PN6	10.8 KN (Max port 80mm)	18.4 KN (Max port 100mm)	31.2 KN (Max port 100mm)	44.8 KN (Max port 100mm)
S.430s	-20°C to +70°C	-50°C to +70°C or -20°C to +120°C	PN6		18.4 KN (Max port 200mm)	31.2 KN (Max port 200mm)	44.8 KN (Max port 200mm)
S.500	-20°C to +70°C	-50°C to +70°C or -20°C to +120°C	PN6		18.4 KN (Max port 200mm)	31.2 KN (Max port 300mm)	44.8 KN (Max port 300mm)
P.250	-30°C to +80°C	-50°C to +80°C or -30°C to +150°C	PN16			31.2 KN (Max port 300mm)	44.8 KN (Max port 300mm)
P.390	-30°C to +80°C	-50°C to +80°C or -30°C to +150°C	PN16			31.2 KN (Max port 300mm)	44.8 KN (Max port 300mm)

(1) = Data calculated with standard construction and 316L SS Stem material.

Special Materials will be considered where the application requires.

## Notes:

Minimum air supply pressure necessary depends on spring range case by case.

Delta2 suggests to consider minimum 0.2 Bar of over-pressure as safety factor to ensure the full stroke of the valve.

Top mounted handwheel and fixed or adjustable stroke limit stop devices are available for all actuators sizes as an optional extra.

Heavy duty side handwheel available on request.



# Pneumatic Actuators Maximum Shutoff Pressure Table

Pressure Drop Table According to ANSI FCI 70.2 Class IV  
Flow to Open - Metal to Metal - Air to Open - Unbalanced Trim

Type	Eff. Area cm <sup>2</sup> (in <sup>2</sup> )	Spring Range Barg (PSIG)	Valve Nominal Size												
			15	20	25	32	40	50	65	80	100	125	150	200	
S.200	130 (20)	0.2 - 1.0 (3 - 15)	12	10	9	3									
		0.4 - 2.0 (6 - 30)	24	20	16	4									
S.275	300 (47)	0.2 - 1.0 (3 - 15)	28	25	16	8	6	4							
		0.4 - 2.0 (6 - 30)	52	47	25	16	12	6							
S.335	470 (73)	0.2 - 1.0 (3 - 15)	58	58	49	19	16	10	4	3	1				
		0.4 - 2.0 (6 - 30)	101	101	82	38	26	18	6	4	2				
S.430	740 (115)	0.2 - 1.0 (3 - 15)	91	89	57	48	37	26	8	5	4	1			
		0.4 - 2.0 (6 - 30)	101	101	101	63	48	37	15	9	6	2			
S.430s	740 (115)	0.4 - 1.4 (6 - 20)						52	13	8	4	2			
		0.8 - 2.0 (12 - 30)						68	21	14	10	5	3	1	
S.500	740 (115)	0.4 - 1.4 (6 - 20)							26	12	9	5	2	1	
		0.8 - 2.0 (12 - 30)							36	21	18	11	5	3	

Pressure Drop Table According to ANSI FCI 70.2 Class IV  
Flow to Open - Metal to Metal - Air to Close - Unbalanced Trim

Type	Eff. Area cm <sup>2</sup> (in <sup>2</sup> )	Air Supplied Pressure Barg	Valve Nominal Size												
			15	20	25	32	40	50	65	80	100	125	150	200	
S.200	130 (20)	3	101	95	60	37	23	15							
		3.5	101	101	75	45	28	18							
S.275	300 (47)	3		101	101	85	55	35	20	13					
		3.5		101	101	101	68	43	26	17					
S.335	470 (75)	3			101	101	86	55	32	21	13				
		3.5			101	101	101	69	41	27	17				
S.430	740 (115)	3				101	101	89	53	35	22	14	9	5.5	
		3.5				101	101	101	66	43	28	17	12	7	
S.430s	740 (115)	3				101	101	101	66	43	28	17	12	7	
		3.5				101	101	101	101	66	35	22	14	9	
S.500	740 (115)	3					101	101	65	43	27	17	12	6.5	
		3.5						101	101	81	53	34	22	15	8.5

**Notes:**

Values indicated in the above tables are calculated and tested with valve standard construction.

Pressure drop shall be always verified with Armstrong Delta 2.

Maximum shutoff pressure indicated is limited to 101 barg to cover PN100/600 at full rating.

Designs, materials, weights and performance ratings are approximate and subject to change without notice.  
Visit [armstronginternational.com](http://armstronginternational.com) for up-to-date information.

# Pneumatic Actuators

## Maximum Shutoff Pressure Table



**Pressure Drop Table According to ANSI FCI 70.2 Class VI**  
**Flow to Open - Soft Seat- Air to Open - Unbalanced Trim**

Type	Eff. Area cm <sup>2</sup> (in <sup>2</sup> )	Spring Range Barg (PSIG)	Valve Nominal Size													
			15	20	25	32	40	50	65	80	100	125	150	200		
S.200	130 (20)	0.2 - 1.0 (3 - 15)	12	10	9	3										
		0.4 - 2.0 (6 - 30)	24	20	16	4										
S.275	300 (47)	0.2 - 1.0 (3 - 15)	28	25	16	8	6	4								
		0.4 - 2.0 (6 - 30)	52	47	25	16	12	6								
S.355	470 (73)	0.2 - 1.0 (3 - 15)	58	58	49	19	16	10	4	3	1					
		0.4 - 2.0 (6 - 30)	101	101	82	38	26	18	6	4	2					
S.430	740 (115)	0.2 - 1.0 (3 - 15)	91	89	57	48	37	26	8	5	4	1				
		0.4 - 2.0 (6 - 30)	101	101	101	63	48	37	15	9	6	2				
S.430s	740 (115)	0.4 - 1.4 (6 - 20)						52	13	8	4	2				
		0.8 - 2.0 (12 - 30)						68	21	14	10	5	3	1		
S.500	740 (115)	0.4 - 1.4 (6 - 20)							26	12	9	5	2	1		
		0.8 - 2.0 (12 - 30)							36	21	18	11	5	3		

**Pressure Drop Table According to ANSI FCI 70.2 Class VI**  
**Flow to Open - Soft Seat- Air to Close - Unbalanced Trim**

Type	Eff. Area cm <sup>2</sup> (in <sup>2</sup> )	Air Supplied Pressure Barg	Valve Nominal Size													
			15	20	25	32	40	50	65	80	100	125	150	200		
S.200	130 (20)	3	101	95	60	37	23	15								
		3.5	101	101	75	45	28	18								
S.275	300 (47)	3		101	101	85	55	35	20	13						
		3.5		101	101	101	68	43	26	17						
S.355	470 (73)	3			101	101	86	55	32	21	13					
		3.5			101	101	101	69	1	27	17					
S.430	740 (115)	3				101	101	89	53	35	22	14	9	5.5		
		3.5				101	101	101	66	43	28	17	12	7		
S.430s	740 (115)	3				101	101	101	66	43	28	17	12	7		
		3.5				101	101	101	101	66	35	22	14	9		
S.500	740 (115)	3					101	101	65	43	27	17	12	6.5		
		3.5					101	101	81	53	34	22	15	8.5		

**Notes:**

Values indicated in the above tables are calculated and tested with valve standard construction.

Pressure Drop shall be always verified with Armstrong Delta 2.

Maximum shutoff pressure indicated is limited to 101 Barg to cover PN100/600# at full rating.

Designs, materials, weights and performance ratings are approximate and subject to change without notice.  
 Visit [armstronginternational.com](http://armstronginternational.com) for up-to-date information.



# Electrical Actuators Maximum Shutoff Pressure Table

**Pressure Drop Table According to ANSI FCI 70.2 Class IV**  
**Flow to Open - Metal to Metal - Fall in Position - Unbalanced Trim**

Type	Action	Thrust KW	Data Sheet	Valve Nominal Size											
				15	20	25	32	40	50	65	80	100	125	150	200
AVM234	On/Off Control	2.5	51.377	40	40	35	24	15	10	6	3.5	2.4	1.5	1.1	0.5
AVF234	On/Off Control	2.0	51.378	40	40	30	18	12	8	4.5	3.2	1.8	1.1		
ST0PA	Control	1.0	STR0PA	40	26	16	10	6	4	2.3	1.5	1			
ST01PA	Control	5.0	STR01PA	40	40	40	40	30	20	12	8	5	3	2.2	1.6
ST1PA	Control	7.5	STR1PA	40	40	40	40	40	29	18	12	7.3	4.5	3	2.3
ST2PA	Control	17.0	STR2PA	40	40	40	40	40	40	40	26.5	17	10.5	7.3	5.3
STMINI	On/Off	1.0	ST MINI	40	26	16	10	6	4	2.3	1.5	1			
ST01	On/Off	5.0	ST.01	40	40	40	40	30	20	12	8	5	3	2.2	1.6
ST1	On/Off	7.5	ST1	40	40	40	40	40	29	18	12	7.3	4.5	3	2.3
ST2	On/Off	17.0	ST2	40	40	40	40	40	40	40	26.5	17	10.5	7.3	5.3

**Pressure Drop Table According to ANSI FCI 70.2 Class VI**  
**Flow to Open - Soft Seat - Fall in Position - Unbalanced Trim**

Type	Action	Thrust KW	Data Sheet	Valve Nominal Size											
				15	20	25	32	40	50	65	80	100	125	150	200
AVM234	On/Off Control	2.5	51.377	40	40	35	24	15	10	6	3.5	2.4	1.5	1.1	0.5
AVF234	On/Off Control	2.0	51.378	40	40	30	18	12	8	4.5	3.2	1.8	1.1		
ST0PA	Control	1.0	STR0PA	40	26	16	10	6	4	2.3	1.5	1			
ST01PA	Control	5.0	STR01PA	40	40	40	40	30	20	12	8	5	3	2.2	1.6
ST1PA	Control	7.5	STR1PA	40	40	40	40	40	29	18	12	7.3	4.5	3	2.3
ST2PA	Control	17.0	STR2PA	40	40	40	40	40	40	40	26.5	17	10.5	7.3	5.3
STMINI	On/Off	1.0	ST MINI	40	26	16	10	6	4	2.3	1.5	1			
ST01	On/Off	5.0	ST.01	40	40	40	40	30	20	12	8	5	3	2.2	1.6
ST1	On/Off	7.5	ST1	40	40	40	40	40	29	18	12	7.3	4.5	3	2.3
ST2	On/Off	17.0	ST2	40	40	40	40	40	40	40	26.5	17	10.5	7.3	5.3

Designs, materials, weights and performance ratings are approximate and subject to change without notice.  
 Visit [armstronginternational.com](http://armstronginternational.com) for up-to-date information.





# Notes

---

A series of horizontal dotted lines for taking notes.

Designs, materials, weights and performance ratings are approximate and subject to change without notice.  
Visit [armstronginternational.com](http://armstronginternational.com) for up-to-date information.



# Armstrong® Valve Dimensions

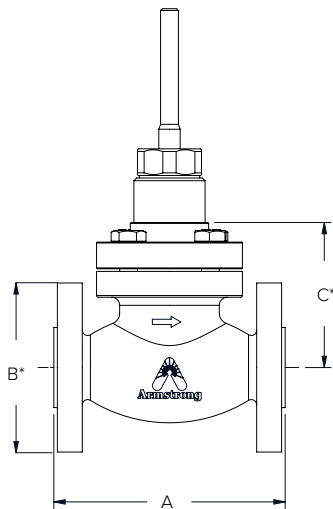

**Standard Bonnet**

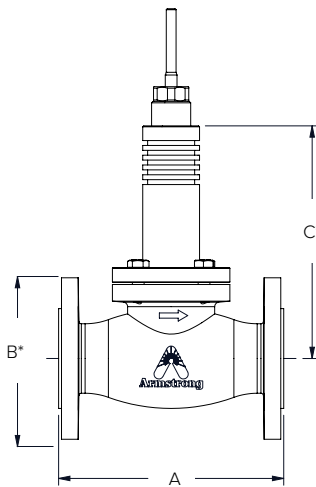

**High Temperature Bonnet**

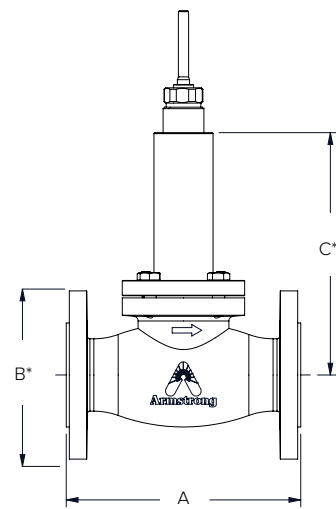

**Bellow Seal - Cryogenic\*\* -  
LeakOff\*\* Bonnet**

Valve DN (inch)	A = Face to Face length (mm) According to EN 558-1 / DIN 3202		C = Bonnet height (mm)			
	PN16 PN25 PN40	PN63 PN100	Standard Bonnet	High Temperature Bonnet	Bellow Seal Bonnet	Cryo Design Bonnet
			Up to PN100	Up to PN100	Up to PN100	Up to PN100
15 (1/2")	130	210	80	165	225	580
20 (3/4")	150	230	80	165	225	580
25 (1")	160	230	85	155	220	585
32 (1-1/4")	180	260	85	160	225	590
40 (1-1/2")	200	260	105	180	235	605
50 (2")	230	300	110	185	240	610
65 (2-1/2")	290	340	160	240	260	660
80 (3")	310	380	170	250	270	670
100 (4")	350	430	185	275	285	690
125 (5")	400	500	230	335	415	730
150 (6")	480	550	250	370	450	750
200 (8")	600	650	280	410	490	780

Valve DN (inch)	A = Face to Face length (mm) According to ANSI/ISA 75.08.01				C = Bonnet height (mm)									
	PN20 (Cl. 125 and 150)		PN50 (Cl. 250 and 300)		Standard Bonnet		High Temp. Bonnet		Bellow Seal Bonnet		Cryo Design Bonnet		Leak Off Bonnet	
	mm	inch.	mm	inch.	mm	inch.	mm	inch.	mm	inch.	mm	inch.	mm	inch.
15 (1/2")	184	7.25	190	7.50	80	3.15	165	6.49	225	8.86	580	22.83	305	12.00
20 (3/4")	184	7.25	194	7.62	80	3.15	165	6.49	225	8.86	580	22.83	305	12.00
25 (1")	184	7.25	197	7.75	85	3.35	155	6.10	220	8.66	585	23.03	300	11.81
40 (1-1/2")	222	8.75	235	9.25	105	4.13	180	7.08	235	9.25	605	23.82	320	15.60
50 (2")	254	10.00	267	10.50	110	4.33	185	7.28	240	9.45	610	24.01	325	12.79
65 (2-1/2")	276	10.88	292	11.50	160	6.30	240	9.45	260	10.24	660	25.98	360	14.17
80 (3")	298	11.75	318	12.50	170	6.69	250	9.84	270	10.63	670	26.38	370	14.56
100 (4")	352	13.88	368	14.50	185	7.28	275	10.83	285	11.22	690	27.16	385	15.16
150 (6")	451	17.75	473	18.62	250	9.84	370	14.56	450	17.72	750	29.53	570	22.44
200 (8")	543	21.38	568	22.38	280	11.02	410	16.14	490	19.29	780	30.71	610	24.00

\* Dimensions B according to DIN EN1092-1 and ASME B16.5 (see page "Valve Connections" on page 6) / Dimension C could change according to special body requirement. \*\* For Cryogenic Bonnet, designed according to BS 6364 and Special Leak Off Bonnet, designed for toxic and lethal service, height could not be modified according to specific process requirement (Consult Armstrong Delta 2)

Designs, materials, weights and performance ratings are approximate and subject to change without notice.  
Visit [armstronginternational.com](http://armstronginternational.com) for up-to-date information.

# Pneumatic Actuators Dimensions

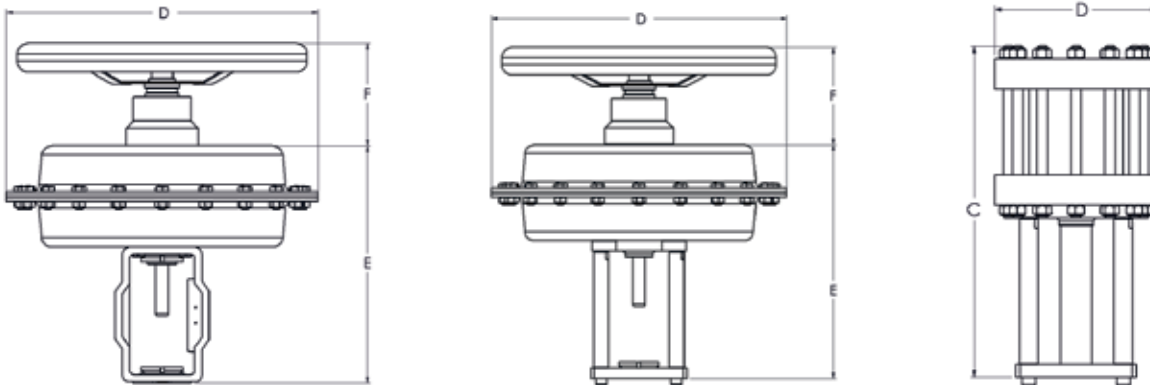

**Diaphragm Actuator Cast Yoke**

**Diaphragm Actuator Pillar Yoke**

**Piston Actuator Pillar Yoke**

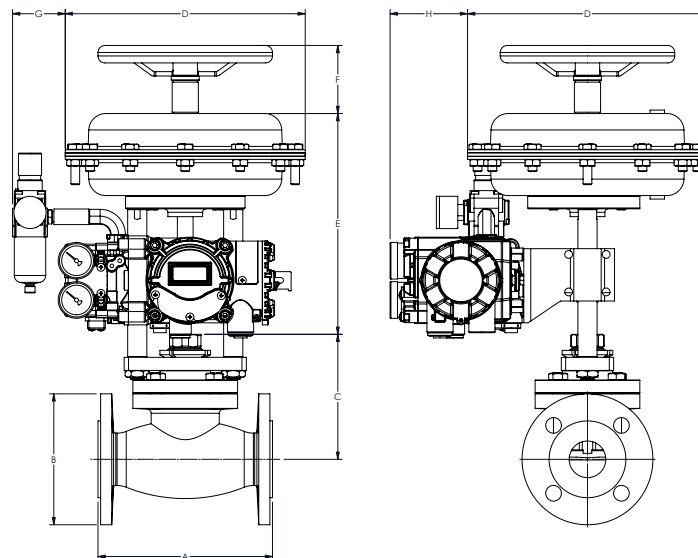

Actuator Type	D = Actuator Diameter (mm)	E = Actuator Height (standard)		F = Top Handwheel		G Filter Regulator (mm)	H Linear Positioner (mm)
		Cast Yoke (mm)	Pillar Yoke (mm)	Maximum Height Reverse Action (mm)	Maximum Height Direct Action (mm)		
S.200	205	235	285	120	150	80	75
S.275	280	265	315	120	150	80	75
S.335	340	275	325	150	180	80	75
S.430	435	355	405	150	180	80	75
S.430s	435	380	465	200	240	80	75
S.500	510	390	430	200	240	80	75
P.250	310	-	557	300	350	80	75
P.390	450	-	557	300	350	80	75

The table above represent the overall dimensions of the valve including the most common accessories (G and H measurements are purely indicative and may change based on the specific models of accessories required).

Designs, materials, weights and performance ratings are approximate and subject to change without notice. Visit [armstronginternational.com](http://armstronginternational.com) for up-to-date information.

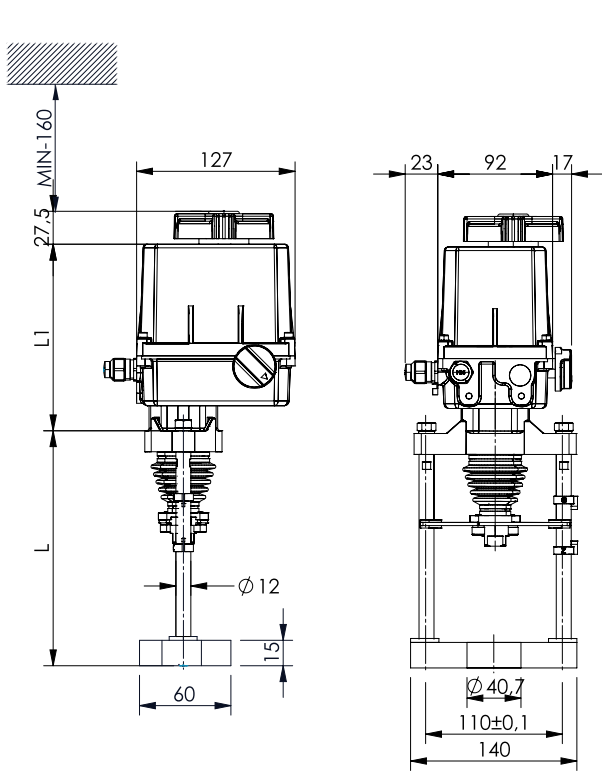

**STROPA**

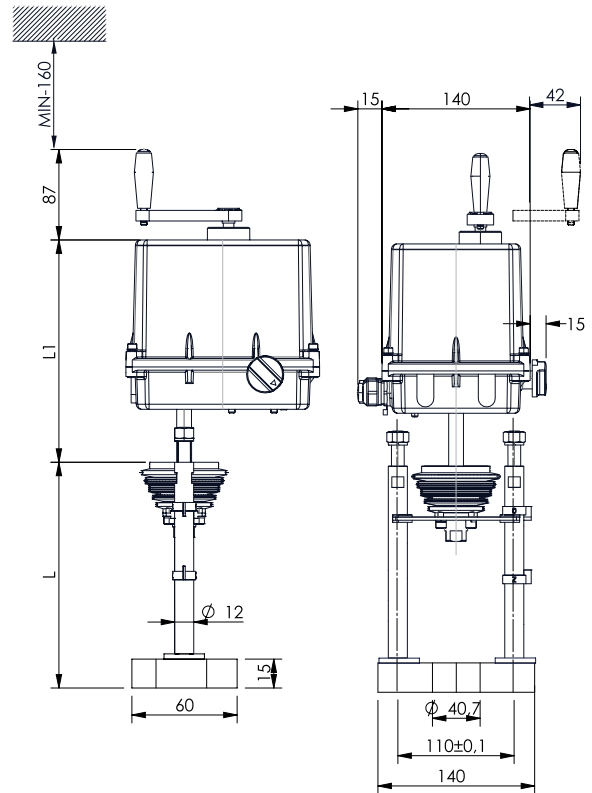

**STRO1PA / ST01**

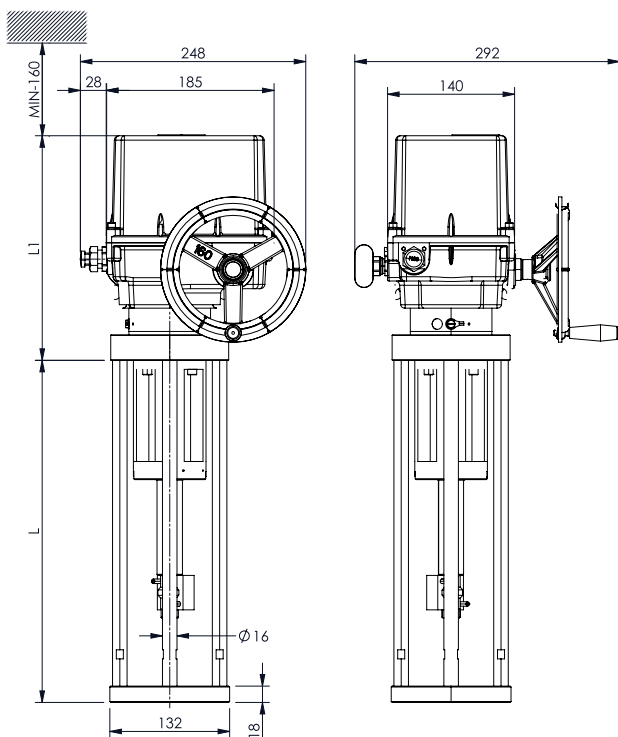

**STR1PA / ST1**

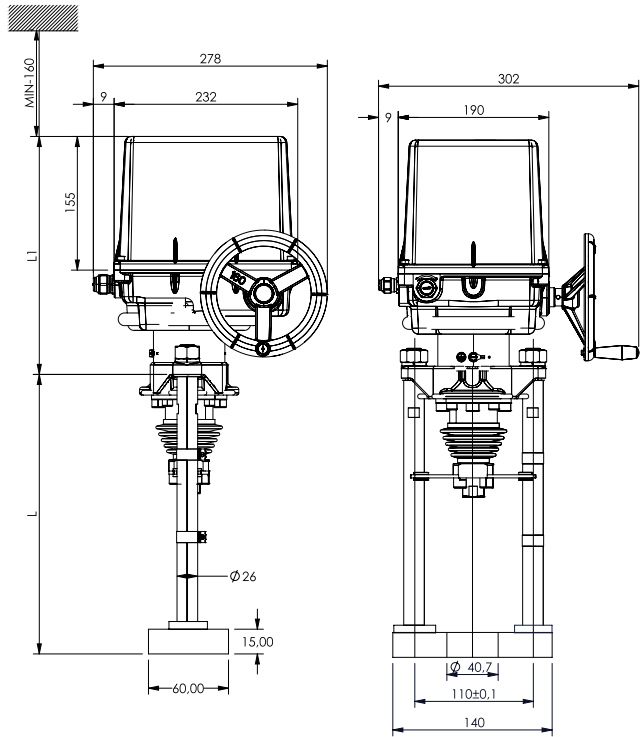

**STR2A / ST2**

Designs, materials, weights and performance ratings are approximate and subject to change without notice. Visit [armstronginternational.com](http://armstronginternational.com) for up-to-date information.

# Electrical Actuators Dimensions

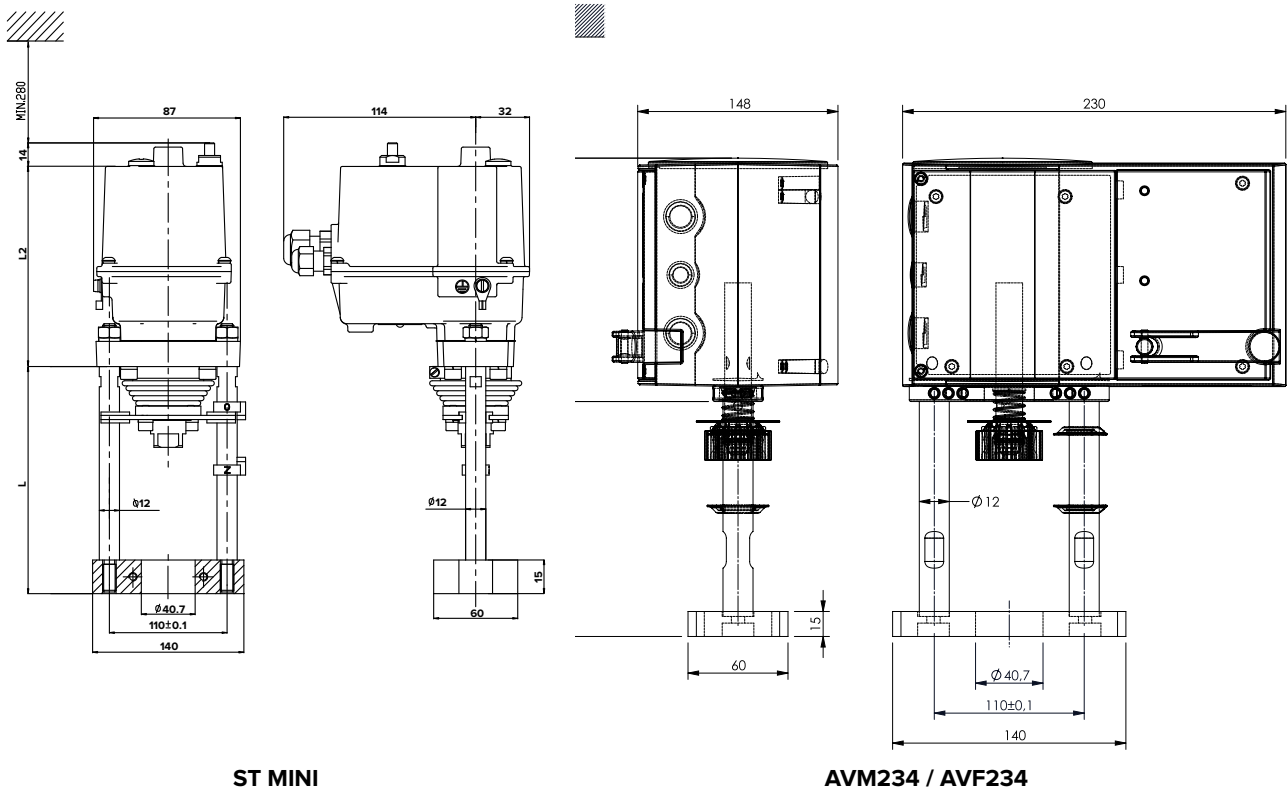

Model	mm	Valve Nominal Size											
		15	20	25	32	40	50	65	80	100	125	150	200
AVM234 AVF234	L/L1	142											
		148											
STMini	L/L1	210											
		119											
STR OPA	L L	210						245					
		165						165					
STR 01PA ST01	L L	210						245					
		210						210					
STR 1PA ST1	L L	210						245					
		248						248					
STR 2PA ST2	L L	210						245					
		302						302					

**Notes:**

The table above represent the overall dimensions of the valve using standard Electrical Actuators, measurements are purely indicative and may change base on the specific models or accessory required.

## Model Number

FLY 15 1 CS ST EU P 275A NO PTFE PPB EQ

Connection Size	
in	mm
1/2	15
3/4	20
1	25
1-1/4	32
1-1/2	40
2	50
2-1/2	65
3	80
4	100

Connection Type	
EN 1092.1 PN16	1
EN 1092.1 PN25	2
EN 1092.1 PN40	3
EN 1092.1 PN63	4
EN 1092.1 PN100	5
ASME B16.5 #150	6
ASME B16.5 #300	7
ASME B16.5 #600	8
EN 10226 BSPT	9
ASME NPT	10
SW ASME B16.11	11
BW ASME B16.25	12

Valve Material	
ASTM A395	CI
ASTM A216	CS
ASTM A351	SS

Bonnet Style	
STANDARD	ST
BELLOW	BE
HIGH TEMPERATURE	HT
CRYOGENIC DESIGN	SR

Packing	
STANDARD	ST
EURO (up to 250 °C)	EU
GRAPHITE (up to 600 °C)	GR
RPTFE (Dangerous Liq.)	RP

Actuator Type	
ELECTRICAL	E
PNEUMATIC	P

Pneumatic Type	
200A	430A
200B	430B
275A	430sA
275B	430sB
335A	500A
335B	500B
NO	

Electric Type	
AVM	STRO
AVF	STR01
STM	STR1
ST01	STR2
ST1	NO
ST2	

Plug Material	
PTFE	(CL. VI)
PEEK	(CL. VI)
MET	(CL. IV)

Trim Type	
PARABOLIC UNBALANCED	PU
PARABOLIC PRESSURE BALANCE	PPB

Trim Characteristic	
EQUAL PERCENTAGE	EQ
LINEAR	LIN

Designs, materials, weights and performance ratings are approximate and subject to change without notice. Visit [armstronginternational.com](http://armstronginternational.com) for up-to-date information.



# Notes

---

A series of horizontal dotted lines spanning the width of the page, intended for handwritten notes.

Designs, materials, weights and performance ratings are approximate and subject to change without notice.  
Visit [armstronginternational.com](http://armstronginternational.com) for up-to-date information.



INTELLIGENT SOLUTIONS IN STEAM, AIR AND HOT WATER

**Armstrong International**

North America • Latin America • India • Europe / Middle East / Africa • China • Pacific Rim

[armstronginternational.eu](http://armstronginternational.eu)